

钱江工业机器人

# QJRB15-1

## INDUSTRIAL ROBOT



- 高速稳定，全轴低功率输出，设备构成简易，可配合专用码垛软件使用；
- 适用于家具、食品饮料、3C等多个行业，实现高速高精度码垛、取件、包装、搬运、上下料。
- High-speed and stable, all axis operating at low power output, simple equipment composition can be used with special palletising software;
- Widely used in intelligent manufacturing industry such as furniture, food and beverage and 3C, applicable to high-speed and high-precision palletizing, picking, packaging, handling, feeding and unloading.

机器人外形尺寸和最大动作范围图

Figure Of Robot Shape Size And Maximum Motion Range

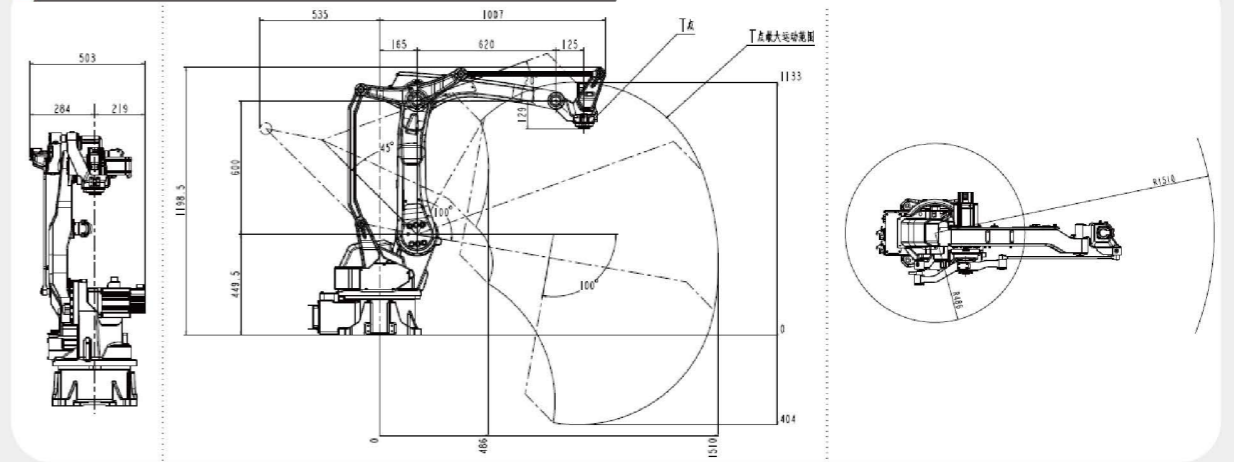

机器人末端安装尺寸图

Dimension Chart Of Robot End - Mounted

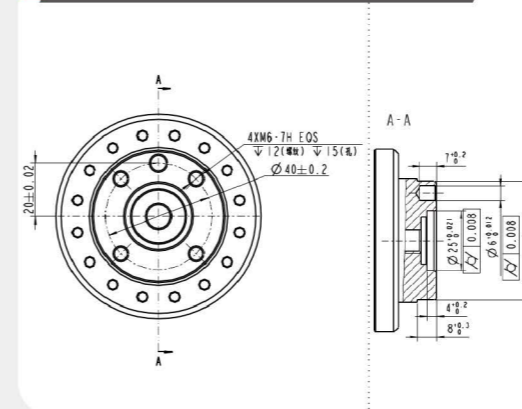

机器人底座安装尺寸图

Mounting Dimensions Of Robot Base

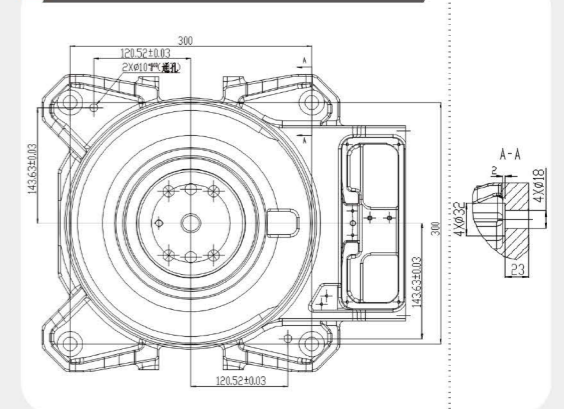

机器人基本规格表

Technical Specifications Of Robot

机构形态 Mechanism	垂直多关节 Vertical multi-joint robot	惯性力矩 Inertia Moment	J4	0.6 kg·m <sup>2</sup>
轴数 Axis Number	4	安装环境 Installation Environment	温度 TEMP	0~45 °C
有效载荷 Payload	15kg	湿度 HUM	20%~80% RH (不结露) No condensation	
重复定位精度 Repeat Positioning	±0.05mm	振动 NVH	<4.9m/s <sup>2</sup> (0.5G)	
最大臂展 Max Armspan	1510mm	其他 Others	避免易燃、腐蚀性气体和液体； Avoid flammable, corrosive gases and liquids;	
防护等级 Protection Degree	IP30		避免接触水、油、粉尘等； Avoid contact with water, oil, dust, etc.;	
本体重量 Robot Body Weight	160kg		勿接近电器噪音源。 Do not approach electrical noise source.	
机械限位范围 Motion Range	J1 ±168° J2 +105°, -50° J3 +105°, -25° J4 ±360°	电源容量 Power Capacity	2.7kVA	
最大速度 Max Speed	J1 195°/s J2 195°/s J3 229°/s J4 544°/s	电控柜尺寸 Cabinet Size	580*600*960mm	
		电控柜重量 Cabinet Weight	100kg	
		电源 Source	单相220V ±10% One-phase -10%	
		安装方式 Installation	地面 Wall	